

This is the Revision D version of the TwinGearSensorLeft RoboBrick. The status of this project is work in progress.

TwinGearSensorLeft Robobrick (Revision D)

Table of Contents

This document is also available in PDF format.

- 1. Introduction
- 2. Hardware
 - ◆ 2.1 Circuit Schematic
 - ◆ 2.2 Printed Circuit Board
- 3. Issues

1. Introduction

The TwinGearSensorLeft board is designed to pick up a quadrature signal from a shaft using two Hamamatsu P5507 chips.

2. Hardware

The hardware consists of a circuit schematic and a printed circuit board.

2.1 Circuit Schematic

The schematic for the TwinGearSensorLeft RoboBrick is shown below:

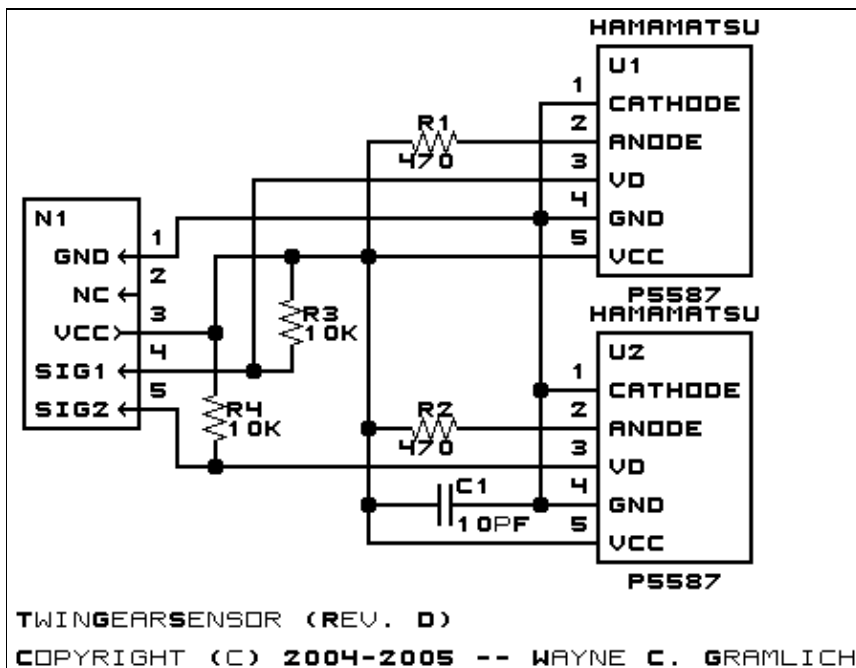

The parts list kept in a separate file -- [twingearsensorleft.ptl](#).

2.2 Printed Circuit Board

The printed circuit board files are listed below:

[twingearsensorleft_back.png](#)

The solder side layer.

[twingearsensorleft_front.png](#)

The component side layer.

[twingearsensorleft_artwork.png](#)

The artwork layer.

[twingearsensorleft.gbl](#)

The RS-272X "Gerber" back (solder side) layer.

[twingearsensorleft.gtl](#)

The RS-272X "Gerber" top (component side) layer.

[twingearsensorleft.gal](#)

The RS-272X "Gerber" artwork layer.

[twingearsensorleft.drl](#)

The "Excellon" NC drill file.

[twingearsensorleft.tol](#)

The "Excellon" tool rack file.

5. Issues

Any fabrication issues that come up are listed here.

Copyright (c) 2004 by Wayne C. Gramlich. All rights reserved.

A. Appendix A: Parts List

```
# TwinGearSensorRight Part List (Rev. D)
#
C1: Capacitor10pF.Small - 10pF Capacitor [Jameco: 15333]
N1: Header1x5.TwinGearSensor - 1x5 Male Header [5/40 Jameco: 160881]
R1-2: Resistor470.Short - 470 Ohm 1/8 Watt Resistor [Digikey: 470EBK-ND]
R3-4: Resistor10K - 10K Ohm 1/4 Watt Resistor [Jameco: 29911]
U1-2: P5587.Long - Hamamatsu P5587 Photo Reflector [Acroname: R65-P5587]
```

B. Appendix B: Artwork Layer

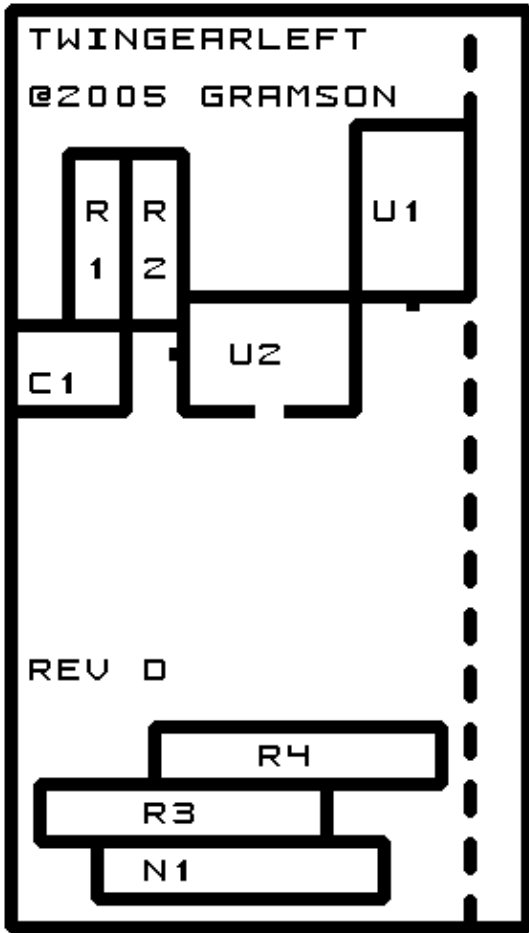

C. Appendix C: Back (Solder Side) Layer

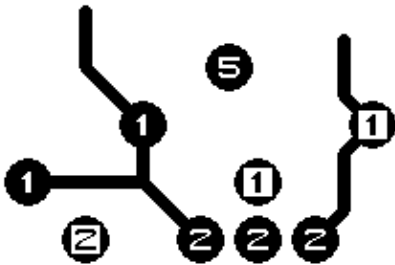
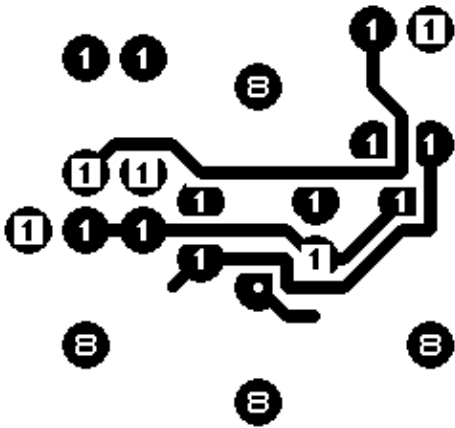

D. Appendix D: Front (Component Side) Layer

