

This is the Revision D version of the [Shaft2 RoboBrick](#). The status of this project is [work in progress](#).

Shaft2 Robobrick (Revision D)

Table of Contents

This document is also available as a [PDF](#) document.

- [1. Introduction](#)
- [2. Programming](#)
- [3. Hardware](#)
 - ◆ [3.1 Circuit Schematic](#)
 - ◆ [3.2 Printed Circuit Board](#)
- [4. Software](#)
- [5. Issues](#)

1. Introduction

The Shaft2 RoboBrick can keep track of the quadrature encoding of 2 shaft encoders.

2. Programming

For quadrature encoding, two sensors are used to sense the shaft position. The sensors are positioned 90 degrees out of phase with one another so that the two sensors generate states of the form 00 – 01 – 11 – 10 – 00 ... in the clockwise direction and 00 – 10 – 11 – 01 – 00 ... in the counter-clockwise direction. Each time the state transitions clockwise, a 16-bit counter is incremented; conversely, each transition in the counter-clockwise direction decrements the 16-bit counter.

The Shaft2 RoboBricks actually use an eight state transition diagram as shown below:

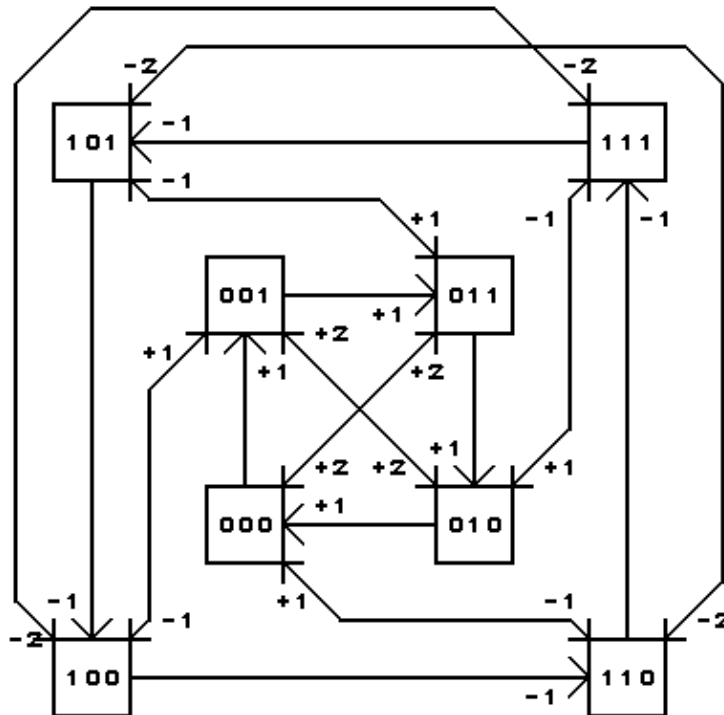

SHAFT2 ROBOBRICK STATE TRANSITION DIAGRAM
COPYRIGHT (C) 2001 -- WAYNE C. GRAMLICH

The first bit is the direction (1=counter-clockwise and 0=clockwise.) The next two bits are the sensor bits. By keeping track of the direction bit as part of the state transition diagram, it is possible to do something intelligent if somehow the shaft is spinning so fast that it skips a state (e.g. 00 - 11 or 01 - 10.) In this case, the direction bit is used to determine whether to increment or decrement the counter by 2.

There are two shafts named shaft 0 and shaft 1. There is an unsigned sixteen bit counter associated with each shaft. Each shaft has both a 16-bit low and a 16-bit high threshold register used for generating interrupts. The interrupt pending bit is set whenever the shaft counter exceeds the range specified by the 16-bit high and low counters. The interrupt pending flag is computed as follows:

$$I = S_0 < L_0 \mid S_0 > H_0 \mid S_1 < L_1 \mid S_1 > H_1$$

where

S_n

is the shaft n counter value,

L_n

is the shaft n low threshold value,

H_n

is the shaft n high threshold value,

Please note that there is no way to individually enable interrupts just for a specific shaft; either both shafts are enabled or neither shaft is enabled.

Shaft2 RoboBrick (Revision D)

In addition to the [common shared commands](#) and the [interrupt protocol](#), the Shaft2 RoboBrick supports the commands summarized in the table below:

Command	Send/ Receive	Byte Value								Discussion
		7	6	5	4	3	2	1	0	
Read Shaft	Send	0	0	0	0	0	0	0	<i>s</i>	Read shaft <i>s</i> and respond with 16-bit counter value <i>hhhhhhhh llllll</i>
	Receive	<i>h</i>	<i>h</i>	<i>h</i>	<i>h</i>	<i>h</i>	<i>h</i>	<i>h</i>	<i>h</i>	
	Receive	<i>l</i>	<i>l</i>	<i>l</i>	<i>l</i>	<i>l</i>	<i>l</i>	<i>l</i>	<i>l</i>	
Read Shaft Low	Send	0	0	0	0	0	0	1	<i>s</i>	Return low order 8-bits <i>lllllll</i> of shaft <i>s</i>
	Receive	<i>l</i>	<i>l</i>	<i>l</i>	<i>l</i>	<i>l</i>	<i>l</i>	<i>l</i>	<i>l</i>	
Set Shaft	Send	0	0	0	0	0	1	0	<i>s</i>	Set counter for shaft <i>s</i> to <i>hhhhhhhh llllll</i>
	Receive	<i>h</i>	<i>h</i>	<i>h</i>	<i>h</i>	<i>h</i>	<i>h</i>	<i>h</i>	<i>h</i>	
	Receive	<i>l</i>	<i>l</i>	<i>l</i>	<i>l</i>	<i>l</i>	<i>l</i>	<i>l</i>	<i>l</i>	
Set Shaft Low	Send	0	0	0	0	0	1	1	<i>s</i>	Set low 8-bits for shaft <i>s</i> to <i>lllllll</i>
	Receive	<i>l</i>	<i>l</i>	<i>l</i>	<i>l</i>	<i>l</i>	<i>l</i>	<i>l</i>	<i>l</i>	
Increment Shaft	Send	0	0	0	0	1	0	0	<i>s</i>	Increment counter for shaft <i>s</i>
Decrement Shaft	Send	0	0	0	0	1	0	1	<i>s</i>	Decrement counter for shaft <i>s</i>
Clear Shaft	Send	0	0	0	0	1	1	0	<i>s</i>	Clear counter for shaft <i>s</i>
Set High Threshold	Send	0	0	0	1	0	0	0	<i>s</i>	Set high threshold for shaft <i>s</i> to <i>hhhhhhhh llllll</i> (default <i>01111111 11111111</i>)
	Send	<i>h</i>	<i>h</i>	<i>h</i>	<i>h</i>	<i>h</i>	<i>h</i>	<i>h</i>	<i>h</i>	
	Send	<i>l</i>	<i>l</i>	<i>l</i>	<i>l</i>	<i>l</i>	<i>l</i>	<i>l</i>	<i>l</i>	
Set Low Threshold	Send	0	0	0	1	0	0	1	<i>s</i>	Set low threshold for shaft <i>s</i> to <i>hhhhhhhh llllll</i> (default <i>10000000 00000000</i>)
	Send	<i>h</i>	<i>h</i>	<i>h</i>	<i>h</i>	<i>h</i>	<i>h</i>	<i>h</i>	<i>h</i>	
	Send	<i>l</i>	<i>l</i>	<i>l</i>	<i>l</i>	<i>l</i>	<i>l</i>	<i>l</i>	<i>l</i>	
Read High Threshold	Send	0	0	0	1	0	1	0	<i>s</i>	Read and return high threshold for shaft <i>s</i> as <i>hhhhhhhh llllll</i>
	Receive	<i>h</i>	<i>h</i>	<i>h</i>	<i>h</i>	<i>h</i>	<i>h</i>	<i>h</i>	<i>h</i>	
	Receive	<i>l</i>	<i>l</i>	<i>l</i>	<i>l</i>	<i>l</i>	<i>l</i>	<i>l</i>	<i>l</i>	
Read Low Threshold	Send	0	0	0	1	0	1	1	<i>s</i>	Read and return high threshold for shaft <i>s</i> as <i>hhhhhhhh llllll</i>
	Receive	<i>h</i>	<i>h</i>	<i>h</i>	<i>h</i>	<i>h</i>	<i>h</i>	<i>h</i>	<i>h</i>	
	Receive	<i>l</i>	<i>l</i>	<i>l</i>	<i>l</i>	<i>l</i>	<i>l</i>	<i>l</i>	<i>l</i>	
Read Interrupt Bits	Send	1	1	1	0	1	<i>c</i>	<i>c</i>	<i>c</i>	Read interrupt enable bit <i>e</i> and interrupt pending bit <i>p</i> .
	Receive	0	0	0	0	0	0	<i>e</i>	<i>p</i>	
Set Interrupt Bits	Send	1	1	1	1	0	<i>c</i>	<i>c</i>	<i>c</i>	Execute set interrupt bits command <i>ccc</i>
Shared Commands	Send	1	1	1	1	1	<i>c</i>	<i>c</i>	<i>c</i>	Execute common shared command <i>ccc</i>

3. Hardware

The hardware consists of a circuit schematic and a printed circuit board.

3.1 Circuit Schematic

The schematic for the Shaft2 RoboBrick is shown below:

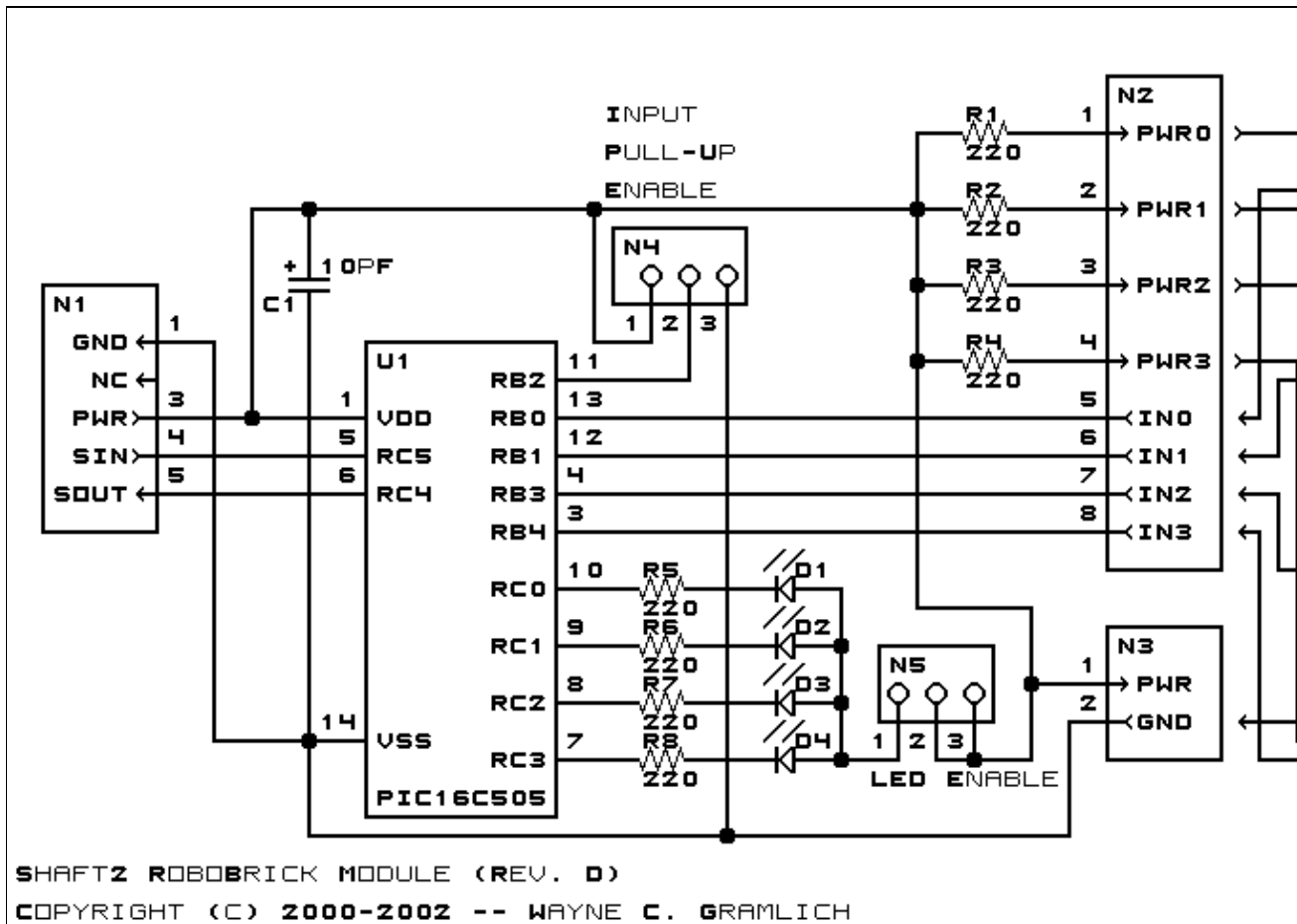

The parts list kept in a separate file --- [shaft2.ptl](#).

3.2 Printed Circuit Board

The printed circuit board files are listed below:

[shaft2_back.png](#)

The solder side layer.

[shaft2_front.png](#)

The component side layer.

[shaft2_artwork.png](#)

The artwork layer.

[shaft2.gbl](#)

The RS-274X "Gerber" back (solder side) layer.

[shaft2.gtl](#)

The RS-274X "Gerber" top (component side) layer.

[shaft2.gal](#)

The RS-274X "Gerber" artwork layer.

[shaft2.drl](#)

The "Excellon" NC drill file.

[shaft2.tol](#)

The "Excellon" tool rack file.

4. Software

The Shaft2 software is available as one of:

[shaft2.ucl](#)

The μ CL source file.

[shaft2.asm](#)

The resulting human readable PIC assembly file.

[shaft2.lst](#)

The resulting human readable PIC listing file.

[shaft2.hex](#)

The resulting Intel[®] Hex file that can be fed into a PIC programmer.

The Shaft2 test suite is available as one of:

[shaft2_test.ucl](#)

The μ CL source file.

[shaft2_test.asm](#)

The resulting human readable PIC assembly file.

[shaft2_test.lst](#)

The resulting human readable PIC listing file.

[shaft2_test.hex](#)

The resulting Intel[®] Hex file that can be fed into a PIC16F84 programmer.

5. Issues

Any fabrication issues are listed here.

[Copyright](#) (c) 2000–2002 by [Wayne C. Gramlich](#). All rights reserved.

A. Appendix A: Parts List

```
# Parts list for Shaft2 RoboBrick (Rev. D)
#
C1: Capacitor10pF - 10 pF Ceramic Capacitor [Jameco: 15333]
D1-4: LEDGreen - Small Green LED [Jameco: 34606]
N1: Header1x5.RBSlave - 1x5 Male Header [5/40 Jameco: 160881]
N2: TerminalStrip8.Shaft2 - 8 Junction Terminal Strip [4 Jameco: 189675]
N3: TerminalStrip2.Shaft2 - 2 Junction Terminal Strip [Jameco: 189675]
N4: Header1x3.Shaft2 - 1x3 Male Header [3/40 Jameco: 160881]
N5: Header1x3.Shaft2 - 1x3 Male Header [3/40 Jameco: 160881]
R1-8: Resistor220.Resistor3 - 220 Ohm 1/4 Wtt Resistor [Jameco: 30470]
U1: PIC16C505.Shaft2 - Microchip PIC16C504 [Digikey: PIC16C505-04/P-ND]
```

B. Appendix B: Artwork Layer

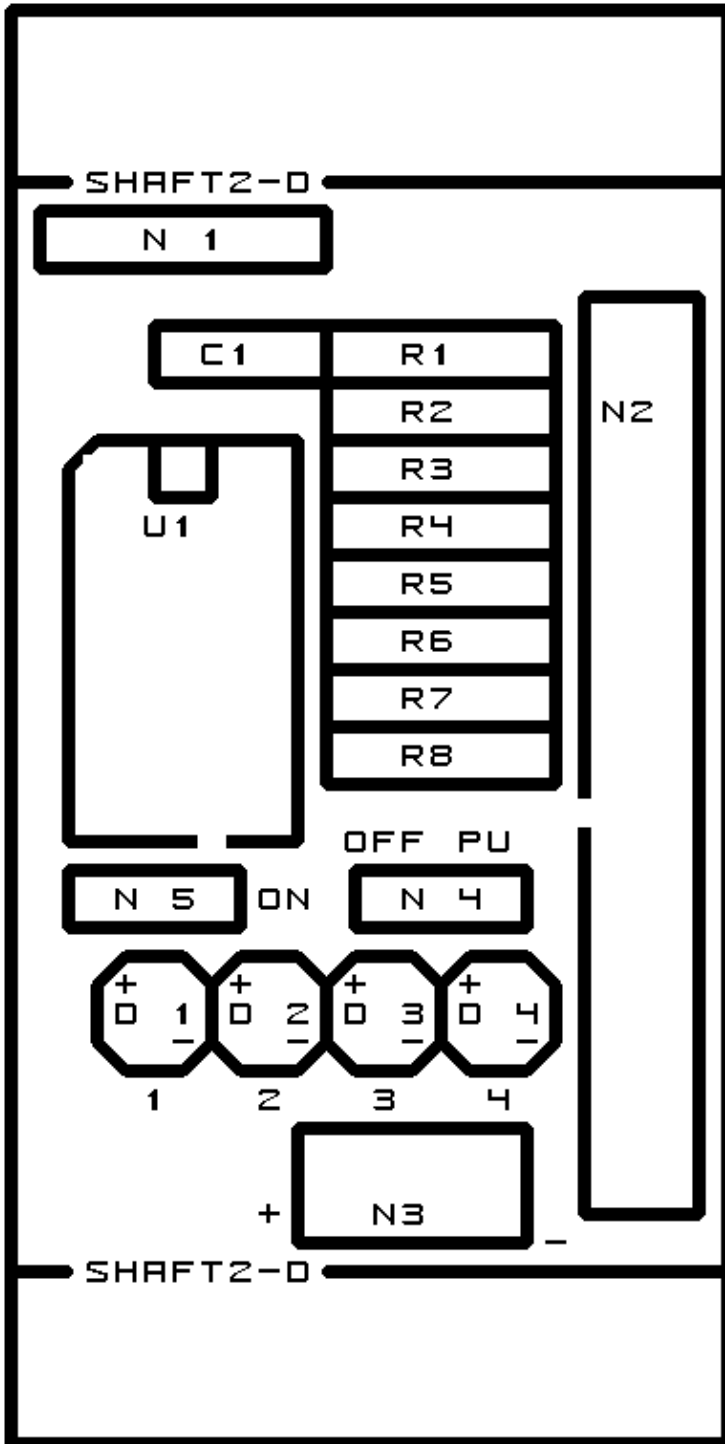

C. Appendix C: Back (Solder Side) Layer

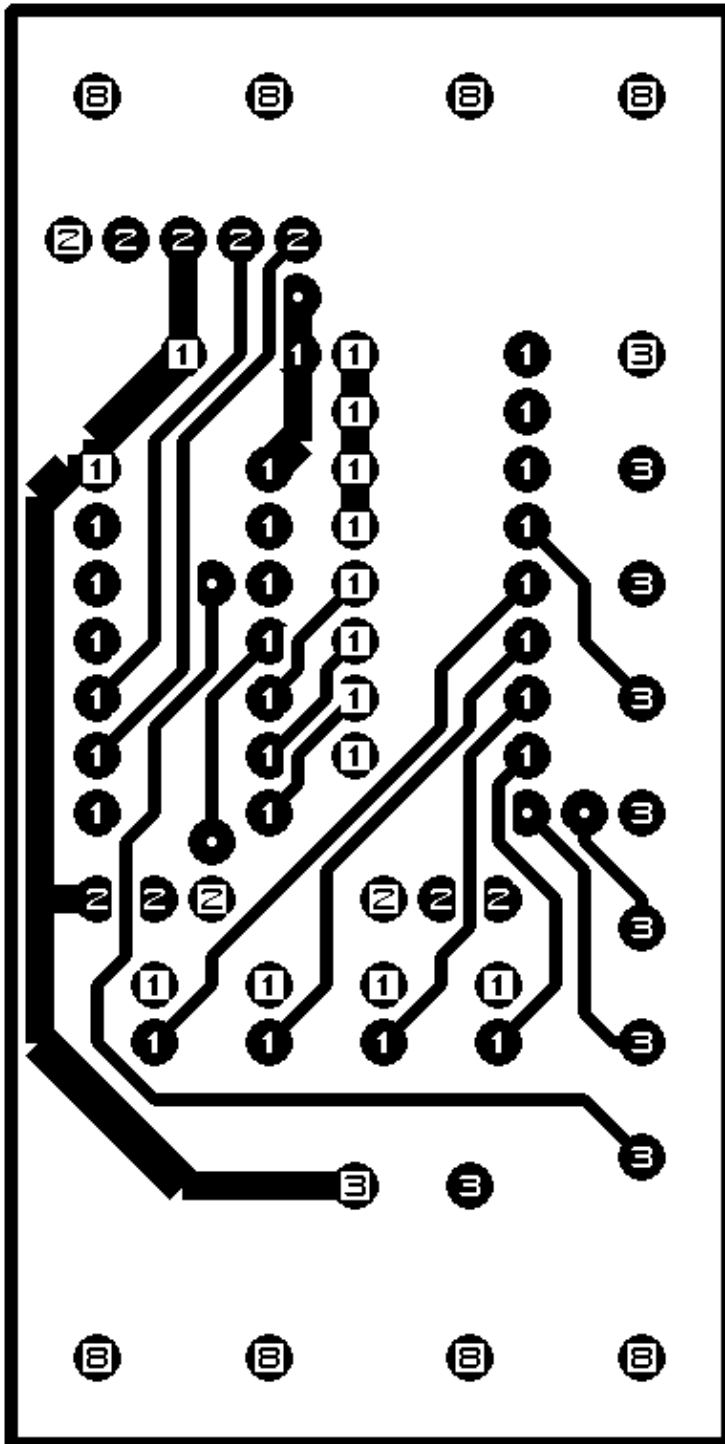

D. Appendix D: Front (Component Side) Layer

