

This is the Revision A version of the Compass8 Module. The status of this project is that it has been replaced by the Revision B version.

Compass8 Module (Revision A)

Table of Contents

This document is also available in PDF format.

- 1. Introduction
- 2. Programming
- 3. Hardware
 - ◆ 3.1 Circuit Schematic
 - ◆ 3.2 Printed Circuit Board
- 4. Software
- 5. Issues

1. Introduction

The Compass8 Module is a Module that can be used to connect to a Dinsmore Instrument Company digital compass. The compass can report the 8 bearings (N, NE, E, SE, S, SW, W, NW.)

A picture of the unpopulated board is shown below:

I currently only have one of the digital compass modules and it has less than ideal behavior. My compass module works best in an environment which has some vibration, otherwise the compass is prone to sticking and can be off by as much as 90 degrees. There is some significant hysteresis as rotation is changed; trying to steer a robot straight by aligning the robot with a bearing boundary (e.g. between N and NE) will not yield a very straight course due to this observed hysteresis effect. Of course, I may have a 'lemon' module and other people might have different experiences with their modules. However, if all you want is basic compass bearing, the Dinsmore digital compass module does seem to meet that requirement at a very reasonable cost.

If you want a more accurate compass module, you might want to try the CMPS01 magnetic compass module available at: Robot Electronics.

2. Programming

The basic operation is to send a query to the Compass8 Module to read the 3 bits of bearing data.

The Compass8 Module supports Module Interrupt Protocol. The interrupt pending bit is set whenever the the formula:

$$B \& M$$

is non-zero, where:

- B is the bearing expanded out into an 8-bit vector with only 1 bit turned on,

Compass8 Module (Revision A)

- M is the interrupt mask, and
- & is bit-wise AND

Once the interrupt pending bit is set, it must be explicitly cleared by the user.

The Compass8 Module supports both the standard shared commands and the shared interrupt commands in addition to the following commands:

Command	Send/ Receive	Byte Value								Discussion
		7	6	5	4	3	2	1	0	
Read Bearing	Send	0	0	0	0	0	0	0	0	Return bearing <i>bbb</i> (N=000, NE=001, E=010, SE=011, S=100, SW=101, W=110, NW=111)
	Receive	0	0	0	0	0	<i>b</i>	<i>b</i>	<i>b</i>	
Read Interrupt Mask	Send	0	0	0	0	0	0	0	1	Return interrupt mask <i>mmmmmmmm</i> (N, NE, E, SE, S, SW, W, NW)
	Receive	<i>m</i>	<i>m</i>	<i>m</i>	<i>m</i>	<i>m</i>	<i>m</i>	<i>m</i>	<i>m</i>	
Read Raw	Send	0	0	0	0	0	0	1	0	Return raw data <i>abcd</i>
	Receive	0	0	0	0	<i>a</i>	<i>b</i>	<i>c</i>	<i>d</i>	
Set Interrupt Mask	Send	0	0	0	0	0	0	1	1	Set interrupt mask to <i>mmmmmmmm</i> (N, NE, E, SE, S, SW, W, NW)
	Receive	<i>m</i>	<i>m</i>	<i>m</i>	<i>m</i>	<i>m</i>	<i>m</i>	<i>m</i>	<i>m</i>	
Read Interrupt Bits	Send	1	1	1	0	1	1	1	1	Return the interrupt pending bit <i>p</i> and the interrupt enable bit <i>e</i> .
	Receive	0	0	0	0	0	0	<i>e</i>	<i>p</i>	
<u>Set Interrupt Commands</u>	Send	1	1	1	1	0	<i>c</i>	<i>c</i>	<i>c</i>	Set Interrupt Command <i>ccc</i> .
<u>Shared Commands</u>	Send	1	1	1	1	1	<i>c</i>	<i>c</i>	<i>c</i>	Execute Shared Command <i>ccc</i> .

3. Hardware

The hardware consists of a circuit schematic and a printed circuit board.

3.1 Circuit Schematic

The schematic for the Compass8 Module is shown below:

Compass8 Module (Revision A)

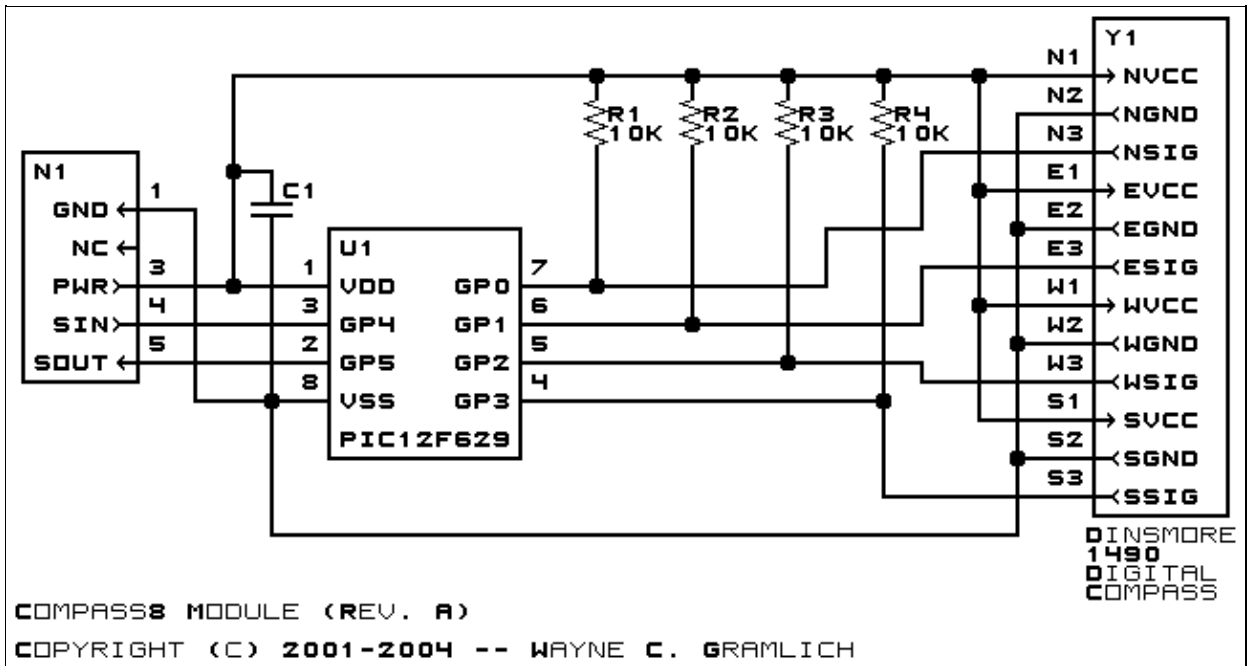

The parts list kept in a separate file -- [compass8.ptl](#).

3.2 Printed Circuit Board

The printed circuit board files are listed below:

[compass8_back.png](#)

The solder side layer.

[compass8_front.png](#)

The component side layer.

[compass8_artwork.png](#)

The artwork layer.

[compass8.gbl](#)

The RS-272X "Gerber" back (solder side) layer.

[compass8.gtl](#)

The RS-272X "Gerber" top (component side) layer.

[compass8.gal](#)

The RS-272X "Gerber" artwork layer.

[compass8.drl](#)

The "Excellon" NC drill file.

[compass8.tol](#)

The "Excellon" tool rack file.

4. Software

The Compass8 software is available as one of:

[compass8.ucl](#)

The μ CL source file.

[compass8.asm](#)

Compass8 Module (Revision A)

The resulting human readable PIC assembly file.

compass8.lst

The resulting human readable PIC listing file.

compass8.hex

The resulting Intel® Hex file.

5. Issues

The following fabrication issues came up:

- The holes for N1 are too large (size 3) and should be made smaller (size 2).
- Think about upgrading to a PIC12C505 and adding three or four indicator LED's; sort of like shaft2.

Copyright (c) 2001–2004 by Wayne C. Gramlich. All rights reserved.